



PLETTAC
MEFRAN
ÉCHAFAUDAGES
VENTE
LOCATION



FT-MXELEV01-A

FICHE TECHNIQUE



Montants d'élévation Métrix

réf. KPT6 / KPT4 / KPT3 / KPT2 / KPT1

Poteau standard 300 cm réf.KPT6 

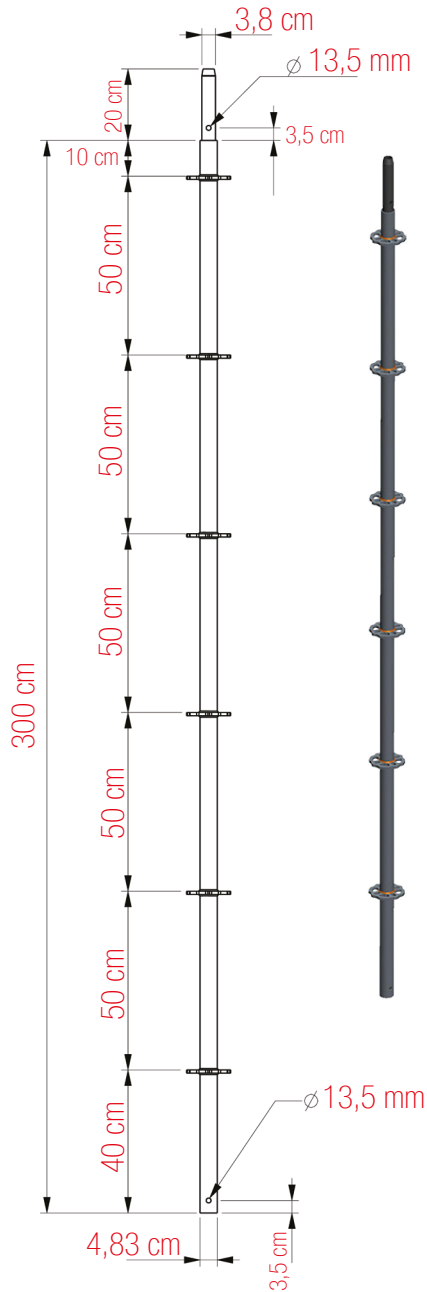

ACIER GALVANISÉ
POIDS : 14,4 kg

Poteau standard 200 cm réf.KPT4 

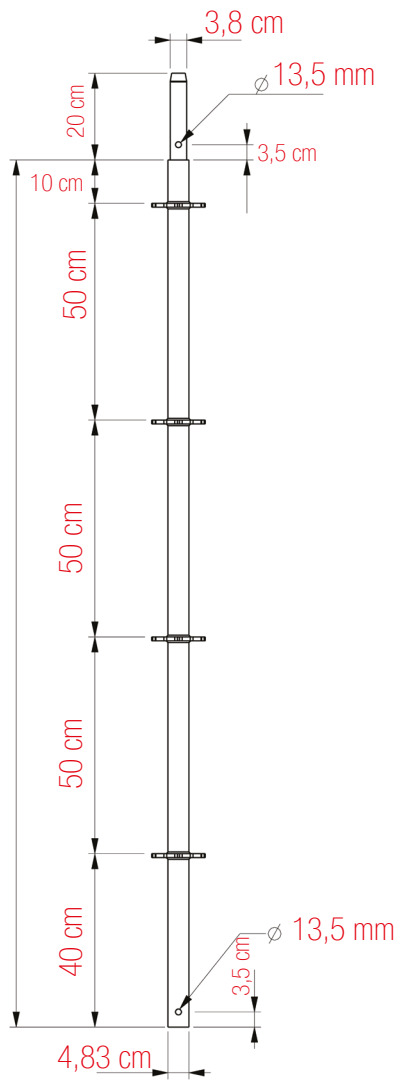

ACIER GALVANISÉ
POIDS : 9,9 kg

MONTANTS D'ÉLEVATION **METRIX**
réf. KPT6 / KPT4 / KPT3 / KPT2 / KPT1

FICHE TECHNIQUE

Montants d'élévation Métrix réf. KPT6 / KPT4 / KPT3 / KPT2 / KPT1

Poteau standard 150 cm réf.KPT3

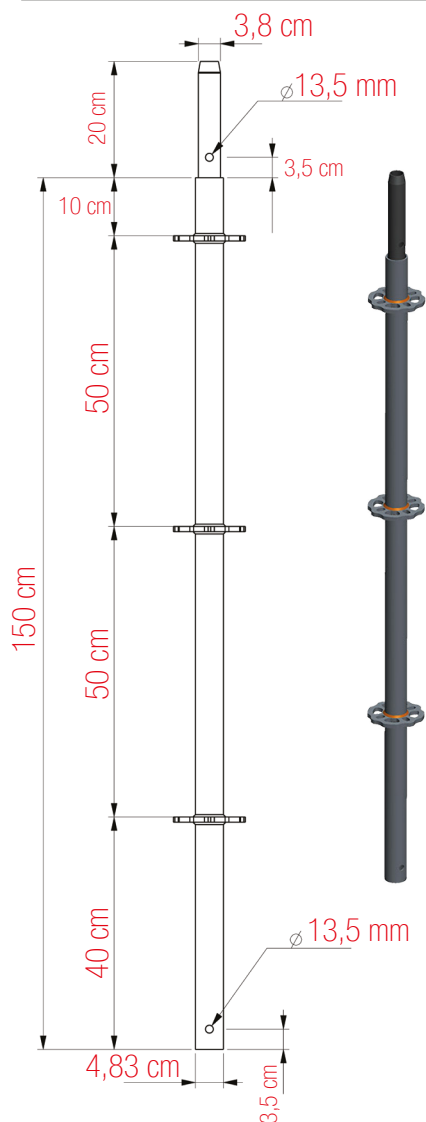

ACIER GALVANISÉ
 POIDS : 7,3 kg

Poteau standard 100 cm réf.KPT2

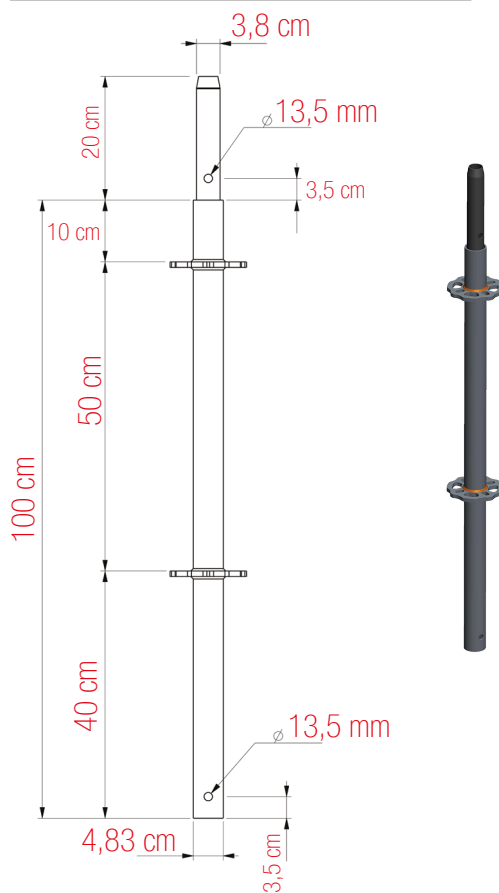

ACIER GALVANISÉ
 POIDS : 5,4 kg



PLETTAC
MEFRAN
ÉCHAFAUDAGES
VENTE
LOCATION



FT-MXELEV01-A

MONTANTS D'ÉLEVATION METRIX
réf. KPT6 / KPT4 / KPT3 / KPT2 / KPT1

FICHE TECHNIQUE

Montants d'élévation Métrix réf. KPT6 / KPT4 / KPT3 / KPT2 / KPT1

Poteau standard 50 cm réf. KPT1

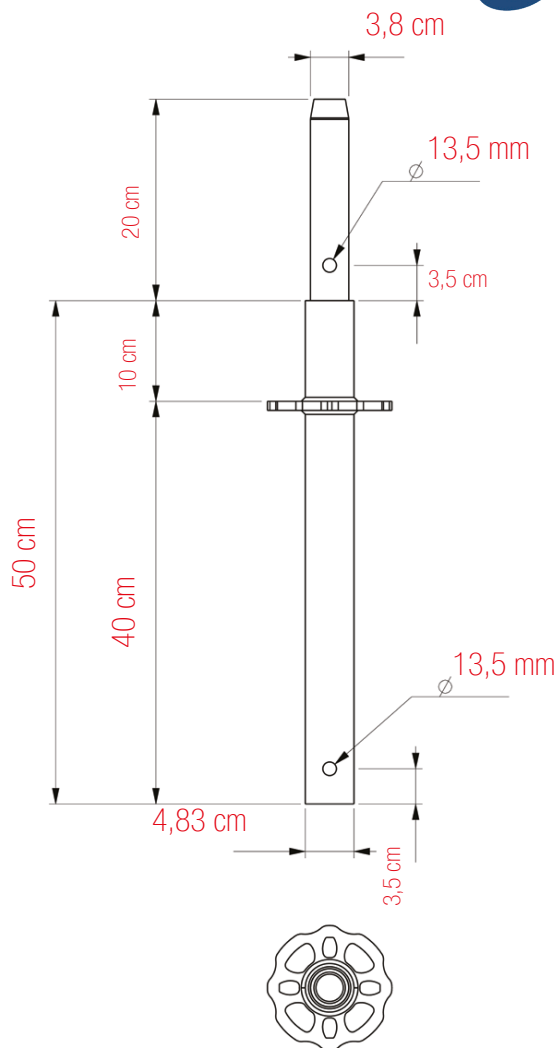

ACIER GALVANISÉ
POIDS : 3 kg

ALTRAD PLETTAC MEFRAN

16 Avenue de la Gardie - 34510 Florensac - FRANCE - Tel. : (+33) 4 67 94 52 29 - Fax. : (+33) 4 67 94 52 23
19 Route d'Ozoir - 77680 Roissy en Brie - FRANCE - Tel. : (+33) 1 60 18 33 33 - Fax. : (+33) 1 60 60 41 68
apm@altrad.com - www.altradplettacmefran.fr

S.A.R.L. au capital de 7 548 420 € - N°SIRET 411 010 424 00033 - TVA intracommunautaire - FR70 411 010 424 - RCS Beziers B411010424 - APE 4663 Z